



Custom Vinyl Products, LLC.

WINDOWS & DOORS

SUBMITTAL PACKAGE

CA55 – Casement Window

Core Sheet	Page 2
Thermal Report	Page 3-6
Structural Report	Page 7-17
Impact Report	<i>Pending</i>
Light Commercial Structural Report	Page 18-29
Warranty	Page 30
Installation Instructions	Page 31
Flashing Detail	Page 32-36
Operating Instructions	<i>Pending</i>

CAD MODEL

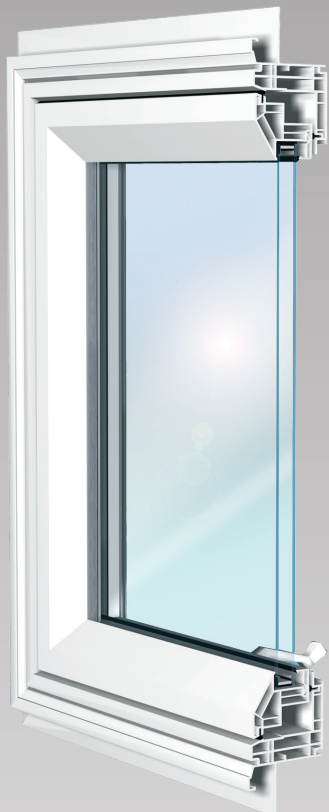

ASSEMBLY DRAWING

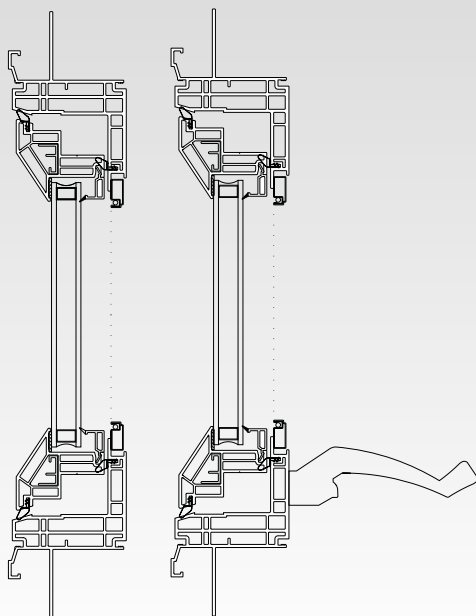

Custom Vinyl Products, LLC
 Window & Door

www.customvinyl.net

Locally Owned & Operated
 Products Certified 100% Lead Free

FEATURES and BENEFITS

- Impact rated grade 50 performance.
- Continuous head and sill with integral mullion.
- All Welded, Brickmold wood window look.
- Multi-point lock system with easy crank operating handle.
- Up to 1" glazing.
- Dual weatherstripping.
- Full 1-3/4" integral nail fin.
- Double wall frame for less roll.
- Strong integral mull reinforcement.
- Factory applied WM-180 brickmold available.
- Factory applied s/4x4 exterior trim.
- One profile sash.
- Common profiles produce Casement, Awning and Picture Windows.
- Accessory options for Bay/Bow applications.
- Stainless steel hardware available.

MANUFACTURING LIMITATIONS

BASELINE PERFORMANCE			
Thermal Insulation			
GLASS	Uc Value	R Value	SHGC
LoE 270	0.27	3.70	.23
LoE 366	0.27	3.70	.17
LoE 366 w/i89	0.23	4.35	.17
Structural Performance			
Air Infiltration @ 25 mph		0.01 cfm/ft ²	
Water Penetration		7.50 psf	
Uniform Loads		+/-75.00 psf	

AAMA RATING: LC-PG50-C





KEYSTONE CERTIFICATIONS, INC.
564 OLD YORK ROAD, SUITE 5
ETTERS, PA 17319 / PHONE 717-932-8500

Notice of Product Certification Authorization

National Fenestration Rating Council

Issued To:

Manufacturer: Custom Vinyl Products LLC
Address: 260 Enterprise Drive
New Port News VA 23603
Man'f Code CST
Cert Date: 6/12/2012

Certification Number

8421

Product Line Number

CST - K - 001

Revision Date

8/31/2015

The Following NFRC Product Line Has Been Authorized For Certification:

Model / Series: CA55 Casement
Operator Type: CSSV
Frame Type: VY
Sash Type: VY
Exp. Date: 9/11/2018

Ratings Authorized For Certification:

Rating	Property	Authorized
NFRC 100	U-factor	<input checked="" type="checkbox"/>
NFRC 200	Solar Heat Gain Coefficient	<input checked="" type="checkbox"/>
NFRC 200	Visible Light	<input checked="" type="checkbox"/>
NFRC 400	Air Leakage	<input checked="" type="checkbox"/>
NFRC 500	Condensation Resistance	<input checked="" type="checkbox"/>

Fenestration products are not NFRC Certified unless manufactured and labeled in accordance with the current version of NFRC-700, Product Certification Program requirements.

***This is a cover sheet for an NFRC Certification Authorization Report (CAR)
the corresponding CAR may be downloaded for printing at www.nfrc.org.***

The Manufacturer is authorized to label the options listed in the corresponding CAR

Please notify Keystone of any errors or omissions within 10 days of receipt.

Due diligence was used in authorizing these products for certification. By accepting this report the licensee agrees to hold harmless and indemnify Keystone Certifications, Inc. from all claims or liabilities which may arise based on this certification authorization. Certification authorization is based on NFRC program requirements and simulation and test reports from accredited laboratories.



NFRC Product Certification Authorization Report

Manufacturer: Custom Vinyl Products, LLC
Product Series: CA55 Casement
Simulation Lab: SATI
Initial Cert. Date: 06/12/2012
Street: 260 Enterprise Drive
Product Type: CSSV
Sim. Report #: D5074.10-116-45
Re-Certification Date: 08/31/2015
City/State/Zip: Newport News, VA 23603
Air Leakage: ≤ 0.3
Sim. Report Date: 06/24/2015
Revised Date: 06/24/2015
Print Date: 08/31/2015
Test Date: 09/11/2014
Expiration Date: 09/11/2018

CPD Number: CST-K-1

JA: Keystone Certifications, Inc.

Status	Product Num.	Manufacturer Code	Frame/Sash	Glaz Lyrs	Low-E (Surface)	Gap Width(s)	Spacer	Gap Fill	Grids	Dividers	Tint	U-Factor	SHGC	VT	Cond. Res.
	00019-00001	E270 / ARG90 / CLR (2MM/2MM) - 3/4"	VY/VY	2	0.037(2)	0.563	SS-D	Fill 1: ARG/AIR (90/10)	N		CL	0.27	0.25	0.47	60
	00019-00002	E270 / ARG90 / CLR (2MM/2MM) - 3/4"	VY/VY	2	0.037(2)	0.563	SS-D	Fill 1: ARG/AIR (90/10)	G	0.75	CL	0.27	0.23	0.42	60
	00019-00003	E270 / ARG90 / CLR (2MM/2MM) - 3/4"	VY/VY	2	0.037(2)	0.563	SS-D	Fill 1: ARG/AIR (90/10)	S	0.75	CL	0.27	0.23	0.42	60
	00020-00001	E366 / ARG90 / CLR (2MM/2MM) - 3/4"	VY/VY	2	0.022(2)	0.563	SS-D	Fill 1: ARG/AIR (90/10)	N		CL	0.27	0.19	0.43	60
	00020-00002	E366 / ARG90 / CLR (2MM/2MM) - 3/4"	VY/VY	2	0.022(2)	0.563	SS-D	Fill 1: ARG/AIR (90/10)	G	0.75	CL	0.27	0.17	0.39	60
	00020-00003	E366 / ARG90 / CLR (2MM/2MM) - 3/4"	VY/VY	2	0.022(2)	0.563	SS-D	Fill 1: ARG/AIR (90/10)	S	0.75	CL	0.27	0.17	0.39	60
	00021-00001	E270 / ARG90 / CLR (3MM/3MM) - 3/4"	VY/VY	2	0.037(2)	0.500	SS-D	Fill 1: ARG/AIR (90/10)	N		CL	0.27	0.25	0.46	60
	00021-00002	E270 / ARG90 / CLR (3MM/3MM) - 3/4"	VY/VY	2	0.037(2)	0.500	SS-D	Fill 1: ARG/AIR (90/10)	G	0.75	CL	0.27	0.23	0.42	60
	00021-00003	E270 / ARG90 / CLR (3MM/3MM) - 3/4"	VY/VY	2	0.037(2)	0.500	SS-D	Fill 1: ARG/AIR (90/10)	S	0.75	CL	0.27	0.23	0.42	60
	00022-00001	E366 / ARG90 / CLR (3MM/3MM) - 3/4"	VY/VY	2	0.022(2)	0.500	SS-D	Fill 1: ARG/AIR (90/10)	N		CL	0.27	0.19	0.43	60
	00022-00002	E366 / ARG90 / CLR (3MM/3MM) - 3/4"	VY/VY	2	0.022(2)	0.500	SS-D	Fill 1: ARG/AIR (90/10)	G	0.75	CL	0.27	0.17	0.39	60
	00022-00003	E366 / ARG90 / CLR (3MM/3MM) - 3/4"	VY/VY	2	0.022(2)	0.500	SS-D	Fill 1: ARG/AIR (90/10)	S	0.75	CL	0.27	0.17	0.39	60
	00023-00001	E366 / ARG90 / i89 (2MM/2MM) - 3/4"	VY/VY	2	0.022(2),0.149(4)	0.563	SS-D	Fill 1: ARG/AIR (90/10)	N		CL	0.23	0.18	0.42	48
	00023-00002	E366 / ARG90 / i89 (2MM/2MM) - 3/4"	VY/VY	2	0.022(2),0.149(4)	0.563	SS-D	Fill 1: ARG/AIR (90/10)	G	0.75	CL	0.23	0.17	0.38	48
	00023-00003	E366 / ARG90 / i89 (2MM/2MM) - 3/4"	VY/VY	2	0.022(2),0.149(4)	0.563	SS-D	Fill 1: ARG/AIR (90/10)	S	0.75	CL	0.23	0.17	0.38	48
	00024-00001	E366 / ARG90 / i89 (3MM/3MM) - 3/4"	VY/VY	2	0.022(2),0.149(4)	0.500	SS-D	Fill 1: ARG/AIR (90/10)	N		CL	0.23	0.18	0.42	47
	00024-00002	E366 / ARG90 / i89 (3MM/3MM) - 3/4"	VY/VY	2	0.022(2),0.149(4)	0.500	SS-D	Fill 1: ARG/AIR (90/10)	G	0.75	CL	0.23	0.17	0.38	47



NFRC Product Certification Authorization Report

Manufacturer: Custom Vinyl Products, LLC
Street: 260 Enterprise Drive
City/State/Zip: Newport News, VA 23603
Print Date: 08/31/2015
Product Series: CA55 Casement
Product Type: CSSV
Air Leakage: ≤ 0.3
Simulation Lab: SATI
Sim. Report #: D5074.10-116-45
Sim. Report Date: 06/24/2015
Test Date: 09/11/2014
Initial Cert. Date: 06/12/2012
Re-Certification Date: 08/31/2015
Revised Date: 06/24/2015
Expiration Date: 09/11/2018

IA: Keystone Certifications, Inc.															
CPD Number:	Product Num.	Manufacturer Code	Frame/Sash	Glaz Lyrs	Low-E (Surface)	Gap Width(s)	Spacer	Gap Fill	Grids	Dividers	Tint	U-Factor	SHGC	VT	Cond. Res.
00024-00003	E366 / ARG90 / i89 (3MM/3MM) - 3/4" IG		VYVY	2	0.022(2),0.149(4)	0.500	SS-D	Fill 1: ARG/AIR (90/10)	S	0.75	CL	0.23	0.17	0.38	47

Baseline Information

Test Lab	Test Date	Test Size	Tested U-Value	Standard U-Value	Test Report Number
TATI	09/11/2014	600mm x 1499mm	0.216	0.213	D5075.10-116-46

Comments: 90% Argon, Single Probe.

I hereby certify that all requirements for NFRC Certification Authorization have been met and that the above information is true and correct, to the best of my knowledge.

2015.09.01 07:46:28
-04'00'

At 2 21

Authorized IA
Signature:



TEST REPORT

Report No.: B5890.03-501-47

Rendered to:

CUSTOM VINYL PRODUCTS
Newport News, Virginia

PRODUCT TYPE: PVC Casement Window
SERIES/MODEL: CA55 CASEMENT

SPECIFICATION: AAMA/WDMA/CSA 101/I.S.2/A440-08, *NAFS - North American Fenestration Standard/Specification for Windows, Doors, and Skylights*

Title	Summary of Results
Primary Product Designator	Class LC-PG50 914 x 1829 (36 x 72) - C
Design Pressure	±2400 Pa (±50.13 psf)
Air Infiltration	0.1 L/s/m ² (0.01 cfm/ft ²)
Water Penetration Resistance Test Pressure	360 Pa (7.52 psf)

Test Completion Date: 12/20/2011

Reference must be made to Report No. B5890.03-501-47, dated 10/31/14 for complete test specimen description and detailed test results.

1.0 Report Issued To: Custom Vinyl Products
260 Enterprise Drive
Newport News, Virginia 23603

2.0 Test Laboratory: Architectural Testing, Inc.
1140 Lincoln Avenue
Springdale, Pennsylvania 15144
724-275-7100

3.0 Project Summary:

3.1 Product Type: PVC Casement Window

3.2 Series/Model: CA55 CASEMENT

3.3 Compliance Statement: Results obtained are tested values and were secured by using the designated test method(s). The specimen tested successfully met the performance requirements for a **Class LC-PG50 914 x 1829 (36 x 72) - C** rating.

This product was originally tested as the Veka Inc. Series/Model CA55WW, PVC Casement Window and is a reissue of the original Report No. B5890.01-501-47. This report is reissued in the name of Custom Vinyl Products through written authorization by Veka Inc.

3.4 Test Dates: 08/07/2011 – 12/20/2011

3.5 Test Location: Veka Inc. test facility in Fombell, Pennsylvania. Calibration of test equipment was performed by Architectural Testing in accordance with AAMA 205-01 "In-Plant Testing Guidelines for Manufacturers and Independent Laboratories".

3.6 Test Sample Source: The test specimen was provided by the client. Representative samples of the test specimen(s) will be retained by Architectural Testing for a minimum of four years from the test completion date.

3.7 Drawing Reference: The test specimen drawings have been reviewed by Architectural Testing and are representative of the test specimen(s) reported herein. Test specimen construction was verified by Architectural Testing per the drawings located in Appendix C. Any deviations are documented herein or on the drawings.

3.8 List of Official Observers:

<u>Name</u>	<u>Company</u>
Doug Merry	Veka Inc.
Cornell Charles	Veka Inc.
Joseph Allison	Architectural Testing, Inc.



4.0 Test Specification(s):

AAMA/WDMA/CSA 101/I.S.2/A440-08, NAFS - North American Fenestration Standard/Specification for Windows, Doors, and Skylights

5.0 Test Specimen Description:

5.1 Product Sizes:

Overall Area: 1.7 m ² (18.0 ft ²)	Width		Height	
	millimeters	inches	millimeters	inches
Overall size	914	36	1829	72
Sash	864	34	1778	70

5.2 Frame Construction:

Frame Member	Material	Description
Head, sill, jambs	PVC	Extruded

	Joinery Type	Detail
All corners	Mitered	Thermally welded

5.3 Vent Construction:

Vent Member	Material	Description
All rails and stiles	PVC	Extruded

	Joinery Type	Detail
All corners	Mitered	Thermally welded



5.0 Test Specimen Description: (Continued)

5.4 Weatherstripping:

Description	Quantity	Location
0.250" diameter hollow rubber bulb with kerf mount base	1 Row	Perimeter of vent, perimeter of frame

5.5 Glazing:

Glass Type	Spacer Type	Interior Lite	Exterior Lite	Glazing Method
3/4" IG	Butyl, single sealed	1/8" annealed	1/8" annealed	The glass was set from the interior against a hot melt sealant and secured with rigid vinyl glazing beads.

Location	Quantity	Daylight Opening		Glass Bite
		millimeters	inches	
Vent	1	756 x 1670	29-3/4 x 65-3/4	1/2"

5.6 Drainage: No drainage was utilized.

5.7 Hardware:

Description	Quantity	Location
Metal multi-point lock system	1	Lock side jamb
Molded plastic tie bar guides	8	Lock side jamb, above and below each lock point
Metal keeper	4	Lock stile at 3-1/2", 23", 42-1/2" and 62" up from the bottom, each fastened to the stile with two #8 x 3/4" flat head screws.
Metal snubber	3 Sets	Hinge stile/jamb, located 9" in from the top and bottom of the stile and at midspan
Steel single arm concealed hinge	2	Head / top rail, and sill / bottom rail
Dual arm rotary operator	1	Sill



5.0 Test Specimen Description: (Continued)

5.8 Reinforcement:

Drawing Number	Location	Material
RF PC02 SOM	All stiles and rails	Roll formed steel
N/A	Lock side stile and bottom rail	3/4" x 1/8" aluminum flat stock

6.0 Installation:

The specimen was installed into a Spruce-Pine-Fir wood buck. The rough opening allowed for a 1/8" shim space. The nail fin perimeter of the window was sealed with silicone sealant.

Location	Anchor Description	Anchor Location
Integral nail fin perimeter	#8 x 1" truss head screw	Spaced nominally 8" on center, beginning at each corner.
Lock side jamb	#8 x 3" flat head screws	Four (4) screws, one each per lock point through a tie bar guide.

7.0 Test Results: The temperature during testing was 20°C (68°F). The results are tabulated as follows:

Title of Test	Results	Allowed	Note
Operating Force, per ASTM E 2068	Initiate motion: 22 N (5 lbf) Maintain motion: 22 N (5 lbf) Locks: 44 N (10 lbf)	Report Only 30 N (7 lbf) max. 100 N (22.5 lbf) max.	
Air Leakage, Infiltration per ASTM E 283 at 75 Pa (1.57 psf)	0.1 L/s/m ² (0.01 cfm/ft ²)	1.5 L/s/m ² (0.3 cfm/ft ²) max.	1
Water Penetration, per ASTM E 547	N/A	N/A	3
Uniform Load Deflection, per ASTM E 330	N/A	N/A	3
Uniform Load Structural, per ASTM E 330	N/A	N/A	3
Forced Entry Resistance, per ASTM F 588, Type: B - Grade: 10	Pass	No entry	
Thermoplastic Corner Weld	Pass	Meets as stated	
Sash Vertical Deflection 200 N (45 lbf)	3.5 mm (0.14")	17.3 mm (0.68") max.	
Distributed Load 300 Pa (6.27 psf)	Pass	No damage	
Optional Performance			
Water Penetration, per ASTM E 547 at 360 Pa (7.52 psf)	Pass	No leakage	2
Uniform Load Deflection, per ASTM E 330 taken at the top rail +2400 Pa (+50.13 psf) -2400 Pa (-50.13 psf)	3.3 mm (0.13") 9.8 mm (0.38")	Report Only	4, 5, 6
Uniform Load Structural, per ASTM E 330 taken at the top rail +3600 Pa (+75.19 psf) -3600 Pa (-75.19 psf)	0.8 mm (0.03") 0.5 mm (0.02")	3.6 mm (0.14") max. 3.6 mm (0.14") max.	5, 6

7.0 Test Results: (Continued)

Note 1: The tested specimen meets (or exceeds) the performance levels specified in AAMA/WDMA/CSA 101/I.S.2/A440 for air leakage resistance.

Note 2: Without insect screen.

Note 3: The client opted to start at a pressure higher than the minimum required. Test results are reported under Optional Performance.

Note 4: The deflections reported are not limited by AAMA/WDMA/CSA 101/I.S.2/A440 for this product designation. The deflection data is recorded in this report for special code compliance and information only.

Note 5: Loads were held for 10 seconds.

Note 6: Tape and film were not used to seal against air leakage during structural testing. In our opinion, the tape and film did not influence the results of the test.



This report is reissued in the name of Custom Vinyl Products through written authorization of Veka Inc. to whom the original report was rendered. The original Veka Inc. Report No. is B5890.01-501-47.

The service life of this report will expire on the stated Test Record Retention End Date, at which time such materials as drawings, data sheets, samples of test specimens, copies of this report, and any other pertinent project documentation, shall be discarded without notice.

If test specimen contains glazing, no conclusions of any kind regarding the adequacy or inadequacy of the glass in any glazed test specimen(s) can be made. This report does not constitute certification of this product nor an opinion or endorsement by this laboratory. It is the exclusive property of the client so named herein and relates only to the specimen(s) tested. This report may not be reproduced, except in full, without the written approval of Architectural Testing, Inc.

For ARCHITECTURAL TESTING, Inc.

Joseph E. Allison/sld

Digitally Signed for: Joseph E. Allison by Sandy L. DiCaro

Joseph E. Allison
Senior Technician

Lynn George

Digitally Signed by: Lynn George

Lynn George
Director - Regional Operations

JEA:sld

Attachments (pages): This report is complete only when all attachments listed are included.
Appendix-A: Alteration Addendum (1)
Appendix-B: Drawings (1) Complete drawings packet on file with Architectural Testing Inc.



Appendix A

Alteration Addendum

Note: *No alterations were required.*



Test Report No.: B5890.03-501-47
Architectural Testing Report Date: 10/31/14
Test Record Retention End Date: 12/20/15

Appendix B

Drawings

Note: Complete drawings packet on file with Architectural Testing, Inc.

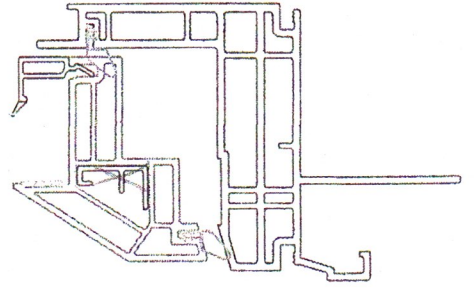
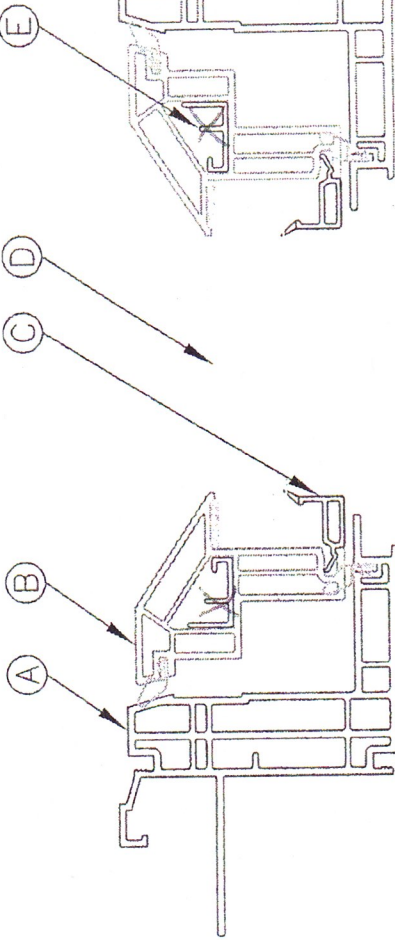
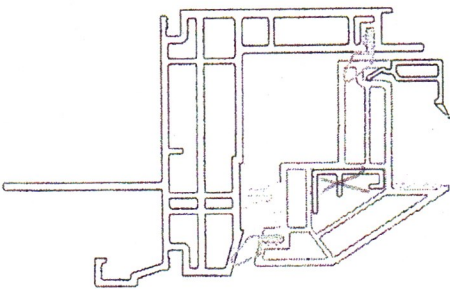

- (A) CA5501 COMMON FRAME
- (B) PC02 COMMON SASH
- (C) BV48 GLAZING BEAD
- (D) 3/4" I.G.
- (E) RFSH37 COMMON REINF.
- X RFL02 50M J



Architectural Testing

Test sample complies with these details.
Deviations are noted.

Report# B5890

Date 1/7/12 Tech pm

AW55WW

VEKA INC.
100 VEKA DRIVE
FOMPELL, PA 16123

DESCRIPTION: 55 SERIES AWNING ASSEMBLY
FULLY WELDED; TRUTH MAXIM HARDWARE

BY: MTN DATE: 06/08/05

C-SIZE SCALE: FULL

REV	ECN	CHANGE	BY	DATE
A	XXXX	XXX	XXX	XX/XX/XX

THIS DOCUMENT CONTAINS CONFIDENTIAL AND PROPRIETARY INFORMATION
DO NOT COPY OR DISCLOSE WITHOUT CONSENT OF VEKA, INC.



TEST REPORT

Report No.: E9466.01-501-47

Rendered to:

VEKA INC.
Fombell, Pennsylvania

PRODUCT TYPE: PVC Casement Window

SERIES/MODEL: CA55WW

SPECIFICATION(S): AAMA/WDMA/CSA 101/I.S.2/A440-11, *NAFS 2011 - North American Fenestration Standard/Specification for Windows, Doors, and Skylights*

AAMA/WDMA/CSA 101/I.S.2/A440-08, *NAFS - North American Fenestration Standard/Specification for Windows, Doors, and Skylights*

Title	Summary of Results
AAMA/WDMA/CSA 101/I.S.2/A440-08 and -11	Class LC-PG50 914 x 1829 (36 x 72) - C
Design Pressure	±2400 Pa (±50.13 psf)
Air Infiltration	0.2L/s/m ² (0.03 cfm/ft ²)
Water Penetration Resistance Test Pressure	360 Pa (7.52 psf)

Test Completion Date: 07/10/15

Reference must be made to Report No. E9466.01-501-47, dated 07/20/15 for complete test specimen description and detailed test results.

1.0 Report Issued To: Veka Inc.
100 Veka Drive
Fombell, Pennsylvania 16123-0250

2.0 Test Laboratory: Architectural Testing, Inc., a subsidiary of Intertek (Intertek-ATI)
1140 Lincoln Avenue
Springdale, Pennsylvania 15144
724-275-7100

3.0 Project Summary:

3.1 Product Type: PVC Casement Window

3.2 Series/Model: CA55WW

3.3 Compliance Statement: Results obtained are tested values and were secured by using the designated test method(s). The specimen tested successfully met the performance requirements for a **Class LC-PG50 914 x 1829 (36 x 72) - C** rating.

3.4 Test Dates: 07/09/15 - 07/10/15

3.5 Test Record Retention End Date: All test records for this report will be retained until July 10, 2019.

3.6 Test Location: Veka Inc. test facility in Fombell, Pennsylvania. Calibration of test equipment was performed by Intertek-ATI in accordance with AAMA 205-01 "In-Plant Testing Guidelines for Manufacturers and Independent Laboratories".

3.7 Test Specimen Source: The test specimen was provided by the client. Representative samples of the test specimen(s) will be retained by Intertek-ATI for a minimum of four years from the test completion date.

3.8 Drawing Reference: The test specimen drawings have been reviewed by Intertek-ATI and are representative of the test specimen(s) reported herein. Test specimen construction was verified by Intertek-ATI per the drawings located in Appendix C. Any deviations are documented herein or on the drawings.

3.9 List of Official Observers:

<u>Name</u>	<u>Company</u>
Doug Merry	Veka Inc.
Cornell Charles	Veka Inc.
Joseph Allison	Intertek-ATI

4.0 Test Specification(s):

AAMA/WDMA/CSA 101/I.S.2/A440-11, *NAFS 2011 - North American Fenestration Standard/Specification for Windows, Doors, and Skylights*

AAMA/WDMA/CSA 101/I.S.2/A440-08, *NAFS - North American Fenestration Standard/Specification for Windows, Doors, and Skylights*

5.0 Test Specimen Description:

5.1 Product Sizes:

Overall Area: 1.7 m ² (18.0 ft ²)	Width		Height	
	millimeters	inches	millimeters	inches
Overall size	914	36	1829	72
Vent size	864	34	1778	70

5.2 Frame Construction:

Frame Member	Material	Description
Head, sill, jambs	PVC	Extruded

	Joinery Type	Detail
All corners	Mitered	Thermally welded

5.3 Vent Construction:

Vent Member	Material	Description
All rails and stiles	PVC	Extruded

	Joinery Type	Detail
All corners	Mitered	Thermally welded

5.4 Weatherstripping:

Description	Quantity	Location
0.300" diameter hollow vinyl bulb with kerf mount base	1 Row	Perimeter of vent, perimeter of frame

5.0 Test Specimen Description: (Continued)

5.5 Glazing: *No conclusions of any kind regarding the adequacy or inadequacy of the glass in any glazed test specimen(s) can be made.*

Glass Type	Spacer Type	Interior Lite	Exterior Lite	Glazing Method
1" IG	Rectangular-shaped steel, single sealed	1/8" annealed	1/8" annealed	The glass was set from the interior against a double sided adhesive tape and secured with rigid vinyl glazing beads.

Location	Quantity	Daylight Opening		Glass Bite
		millimeters	inches	
Vent	1	756 x 1670	29-3/4 x 65-3/4	1/2"

5.6 Drainage: No drainage was utilized.

5.7 Hardware:

Description	Quantity	Location
Metal multi-point lock system	1	Lock side jamb
Molded plastic tie bar guides	8	Lock side jamb, above and below each lock point
Metal keeper	4	Lock stile at 3", 25", 45-1/2" and 65-1/2" up from the bottom, each fastened to the stile with two #8 x 3/4" flat head screws.
Metal snubber	3 Sets	Hinge stile/jamb, located 1/4 points and at midspan
Steel single arm concealed hinge	2	Head / top rail, and sill / bottom rail
Dual arm rotary operator	1	Sill

5.8 Reinforcement:

Drawing Number	Location	Material
RF SH37 AOM	All stiles and rails	Extruded aluminum



6.0 Installation:

The specimen was installed into a Spruce-Pine-Fir wood buck. The rough opening allowed for a 1/8" shim space. The nail fin perimeter of the window was sealed with silicone sealant.

Location	Anchor Description	Anchor Location
Integral nail fin perimeter	#8 x 1" truss head screw	Nominally spaced at 9" on center, beginning at each corner.
Lock side jamb	#8 x 3" flat head screws	One at each tie bar guide (4)

7.0 Test Results: The temperature during testing was 21°C (70°F). The results are tabulated as follows:

Test Specimen #1:

Title of Test	Results	Allowed	Note
Operating Force, per ASTM E 2068	Initiate motion: 22 N (5 lbf) Maintain motion: 22 N (5 lbf) Locks: 44 N (10 lbf)	Report Only 30 N (7 lbf) max. 100 N (22.5 lbf) max.	
Air Leakage, Infiltration per ASTM E 283 at 75 Pa (1.57 psf)	0.2 L/s/m ² (0.03 cfm/ft ²)	1.5 L/s/m ² (0.3 cfm/ft ²) max.	1
Water Penetration, per ASTM E 547	N/A	N/A	3
	Pass	No leakage	2
Uniform Load Deflection, per ASTM E 330	N/A	N/A	3
Uniform Load Structural, per ASTM E 330	N/A	N/A	3
Forced Entry Resistance, per ASTM F 588, Type: B - Grade: 10	Pass	No entry	
Thermoplastic Corner Weld	Pass	Meets as stated	
Title of Test	Results	Allowed	Note
Sash Vertical Deflection 200 N (45 lbf)	3.5 mm (0.14")	17.3 mm (0.68") max.	
Distributed Load 300 Pa (6.27 psf)	Pass	No damage	
Optional Performance			
Water Penetration, per ASTM E 547 at 360 Pa (7.52 psf)	Pass	No leakage	2
Uniform Load Deflection, per ASTM E 330 taken at the top rail +2400 Pa (+50.13 psf) -2400 Pa (-50.13 psf)	1.8 mm (0.07") 8.0 mm (0.32")	Report Only	4, 5, 6
Uniform Load Structural, per ASTM E 330 taken at the top rail +3600 Pa (+75.19 psf) -3600 Pa (-75.19 psf)	0.3 mm (0.01") 0.8 mm (0.03")	3.6 mm (0.14") max. 3.6 mm (0.14") max.	5, 6

7.0 Test Results: (Continued)

Note 1: The tested specimen meets (or exceeds) the performance levels specified in AAMA/WDMA/CSA 101/I.S.2/A440 for air leakage resistance.

Note 2: Without insect screen.

Note 3: The client opted to start at a pressure higher than the minimum required. Test results are reported under Optional Performance.

Note 4: The deflections reported are not limited by AAMA/WDMA/CSA 101/I.S.2/A440 for this product designation. The deflection data is recorded in this report for special code compliance and information only.

Note 5: Loads were held for 10 seconds.

Note 6: Tape and film were used to seal against air leakage during structural testing. In our opinion, the tape and film did not influence the results of the test.

Intertek-ATI will service this report for the entire test record retention period. Test records such as detailed drawings, datasheets, representative samples of test specimens, or other pertinent project documentation, will be retained by Intertek-ATI for the entire test record retention period.

This report does not constitute certification of this product nor an opinion or endorsement by this laboratory. It is the exclusive property of the client so named herein and relates only to the specimen(s) tested. This report may not be reproduced, except in full, without the written approval of Intertek-ATI.

For INTERTEK-ATI.

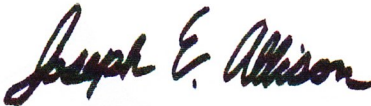

Digitally Signed by: Joseph E. Allison

Joseph E. Allison
Senior Technician

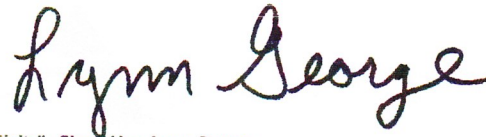

Digitally Signed by: Lynn George

Lynn George
Director - Regional Operation

JEA:sld

Attachments (pages): This report is complete only when all attachments listed are included.

Appendix-A: Alteration Addendum (1)

Appendix-B: Location of Air Seal (1)

Appendix- C: Drawing(s) (1) Complete drawings packet on file with Intertek-ATI.



Appendix A
Alteration Addendum

Note: No alterations were required.

Appendix B

Location of Air Seal: The air seal between the test specimen and the test wall is detailed below. The seal is made of foam weatherstripping and is attached to the edge of the test specimen buck. The test specimen buck is placed against the test wall and clamped in place, compressing the weatherstripping and creating a seal.

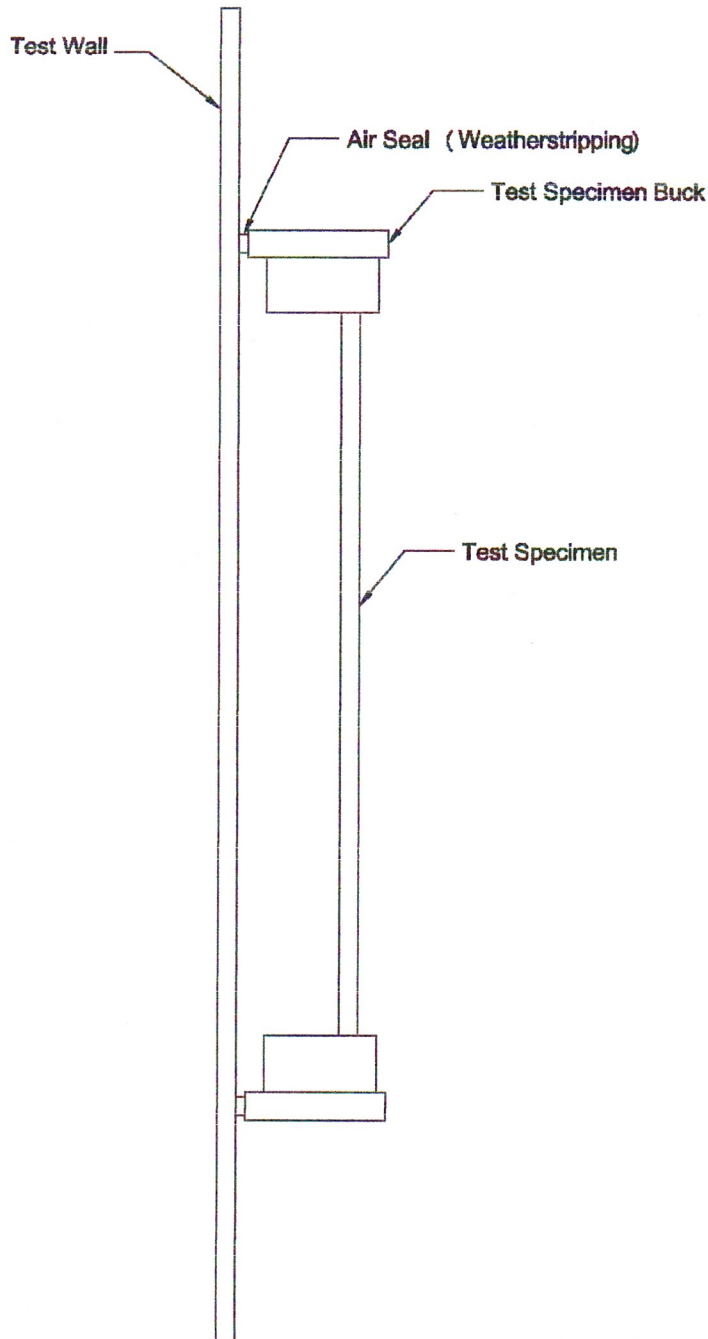



Appendix C

Drawing(s)

Note: Complete drawings packet on file with Intertek-ATI.

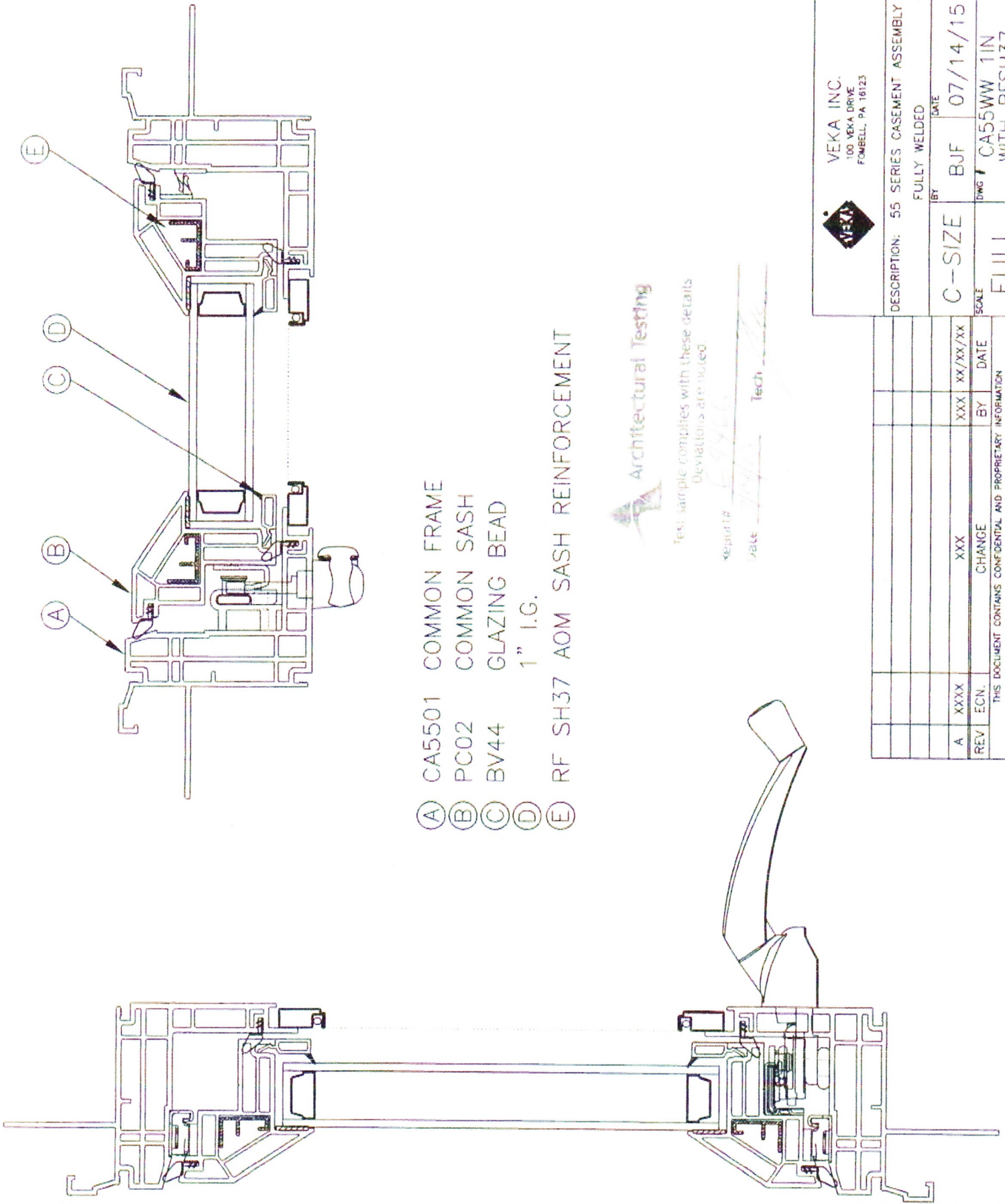

- (A) CA5501 COMMON FRAME
- (B) PC02 COMMON SASH
- (C) BV44 GLAZING BEAD
- (D) 1" I.G.
- (E) RF SH37 AOM SASH REINFORCEMENT

Architectural Testing

Test sample complies with these details
 Deviations are noted

Report # *10/14/15* Tech *[Signature]*
 Date *10/14/15*

VEKA INC.
 100 VEKA DRIVE
 FOMPELL, PA 16123

DESCRIPTION: 55 SERIES CASEMENT ASSEMBLY
 FULLY WELDED

BY B J F DATE 07/14/15
 C-SIZE

SCALE FULL DWG # CA55WW 1IN WITH RFSH37

REV	ECN.	CHANGE	BY	DATE
A	XXXX	XXX	XXX	XX/XX/XX

THIS DOCUMENT CONTAINS CONFIDENTIAL AND PROPRIETARY INFORMATION
 DO NOT COPY OR DISCLOSE WITHOUT CONSENT OF VEKA, INC.



Limited Lifetime Warranty

Windows and sliding patio doors manufactured by **Custom Vinyl Products, LLC Windows and Doors** are guaranteed to be free of defects in material and workmanship under normal use and conditions. This Limited Warranty extends from the first date of purchase to the original owner and is subject to the terms and conditions stated herein:

- ❖ Vinyl components will be free from blistering, peeling, flaking, rotting, yellowing, or corrosion for the life of the product with the following exception:
 - Painted vinyl finishes – 10 years
 - Euroview vinyl products – 25 years
- ❖ There will be no material obstruction of vision on the internal surfaces of the insulated glass unit caused by seal failure for a period of 25 years with the following exceptions:
 - Laminated glass – 5 years
 - Architectural shaped glass – 10 years
 - Euroview product glass – 10 years
- ❖ Component parts will be covered for a period of 2 years with the following exceptions:
 - Motorized awning operators – 1 year
 - Screens – 90 days

The terms of this Limited Warranty exclude failures which are a result of or involve:

- ❖ Improper installation
- ❖ Accident, negligence, abuse, alteration, or improper use
- ❖ Excessive exposure to heat and cold outside of normal conditions
- ❖ Exposure to caustic agents
- ❖ Torn or damaged screens
- ❖ Glass breakage for any reason
- ❖ Corrosion of non-vinyl components in coastal areas, unless product is assembled with appropriate stainless steel hardware
- ❖ Condensation on external surfaces
- ❖ Failures caused by movement, expansion, or contraction of building or building components

This Limited Warranty covers materials only, and Custom Vinyl Products, LLC does not assume any expense or responsibility involved with the removal or reinstallation of replacement parts or any indirect, consequential, or incidental damage.



CUSTOM VINYL PRODUCTS, LLC

WINDOW INSTALLATION INSTRUCTIONS

- 1) Check that rough opening is between ½" to ¾" larger than the dimensions of the window, height and width.
- 2) Cut house wrap at 45 degree angle from top corners, about 6", and tack up out of the way.
- 3) Place wood shims in bottom right hand corner of the window opening.
- 4) Apply continuous ¼" bead of silicone based caulk to the inside of the nailing flange on the sides and top only.
- 5) Place window unit in the opening. **Sash must be locked during installation.** Rest window against shims in the right hand corner.
- 6) Attach the window using 1 ½" galvanized roofing nails through upper right side of nail fin. **Use pre-punched nail slots. Never use automated nailing devices.**
- 7) Place 2 foot level against left side of jamb and lift left side of window into level position.
- 8) Fasten head jamb.
- 9) Shim left and right side of jambs as to maintain a 1/16" continuous margin between sash and frame.
- 10) Fasten left side of jamb.
- 11) Attach the remainder of the unit approximately every other nail slot.
- 12) Check sash for easy operation. Check margins between sash and frame along the sides as well as top and bottom.
- 13) Apply 4" window flashing tape around the perimeter of the window, sides first then top. **Do not tape the bottom of the window.**

****FOR FURTHER FLASHING INSTRUCTIONS GO TO CUSTOMVINYL.NET**

CAUTION: GENERAL CONTRACTORS

- Keep sill area free of all debris. Do not allow brick or mortar to touch edges of window frame. Allow 1/8" gap and seal with caulk.
- Never use expandable foam insulation between window and rough opening. Use bat insulation.
- Window sash must always be locked during installation.

OPERATING INSTRUCTIONS

- 1) ALWAYS raise the sash before attempting to tilt.
- 2) Sash removal: Raise sash, tilt 90 degrees, and lift at each corner.
- 3) If the sash will not move up or down, remove sash as instructed above and repeat the process.

DuPont™ Flashing Systems Installation Guidelines

Installation Methods for DuPont™ Flashing System AFTER Water-Resistive Barrier (WRB) is Installed

Integral Flanged Window AFTER Water-Resistive Barrier (WRB)

Method applies to following product:

- DuPont™ StraightFlash™
- DuPont™ FlexWrap™

STEP 1

Prepare water-resistive barrier for window installation:

- Make an "I-Cut" (Standard I-Cut) in the WRB (modified I-Cut is also accepted). For an "I-Cut" begin with a horizontal cut across the bottom and the top of the window frame (for round top windows, the cut should begin 2" above the mull joint [see D]). From the center cut straight down to the sill.
- Cut two 45 degree slits a minimum of 8" from the corner of the header to create a flap above the rough opening to expose sheathing or framing members to allow head flashing installation (see step 5). Flip head flap up and temporarily secure with DuPont™ Tyvek® Tape. Some windows and flashing widths may require longer slits.
- Fold side flaps into rough opening, cut excess flaps, and secure.

Note: Side flaps should cover interior facing framing stud.

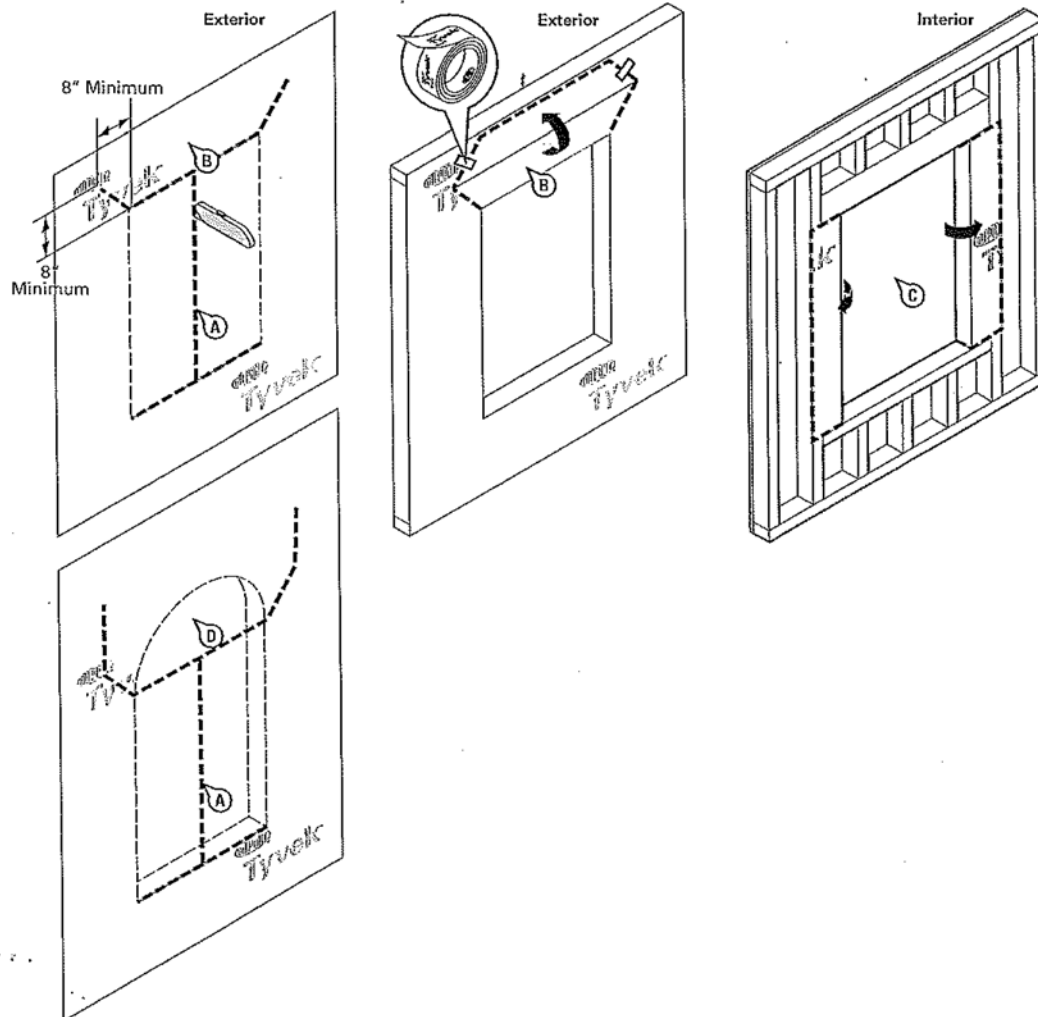

STEP 2 (optional / not required)

- A. Cut DuPont™ FlexWrap™ at least 12" longer than width of rough opening sill (S).
- B. Remove first piece of release paper, cover horizontal sill by aligning inside edge of sill, and adhere into rough opening along sill and up jambs (min. 6" on each side).
- C. Remove second release paper.
- D. Flex DuPont™ FlexWrap™ at bottom corners onto face of wall.
- E. **SECURE EDGES OF DUPONT™ FLEXWRAP™ WITH MECHANICAL FASTENERS.** i.e., DuPont™ Tyvek® Wrap Caps (nails, screws, staples).

Note: Secure fastener along the bottom outer edge of the DuPont™ FlexWrap™ at flexed corners.

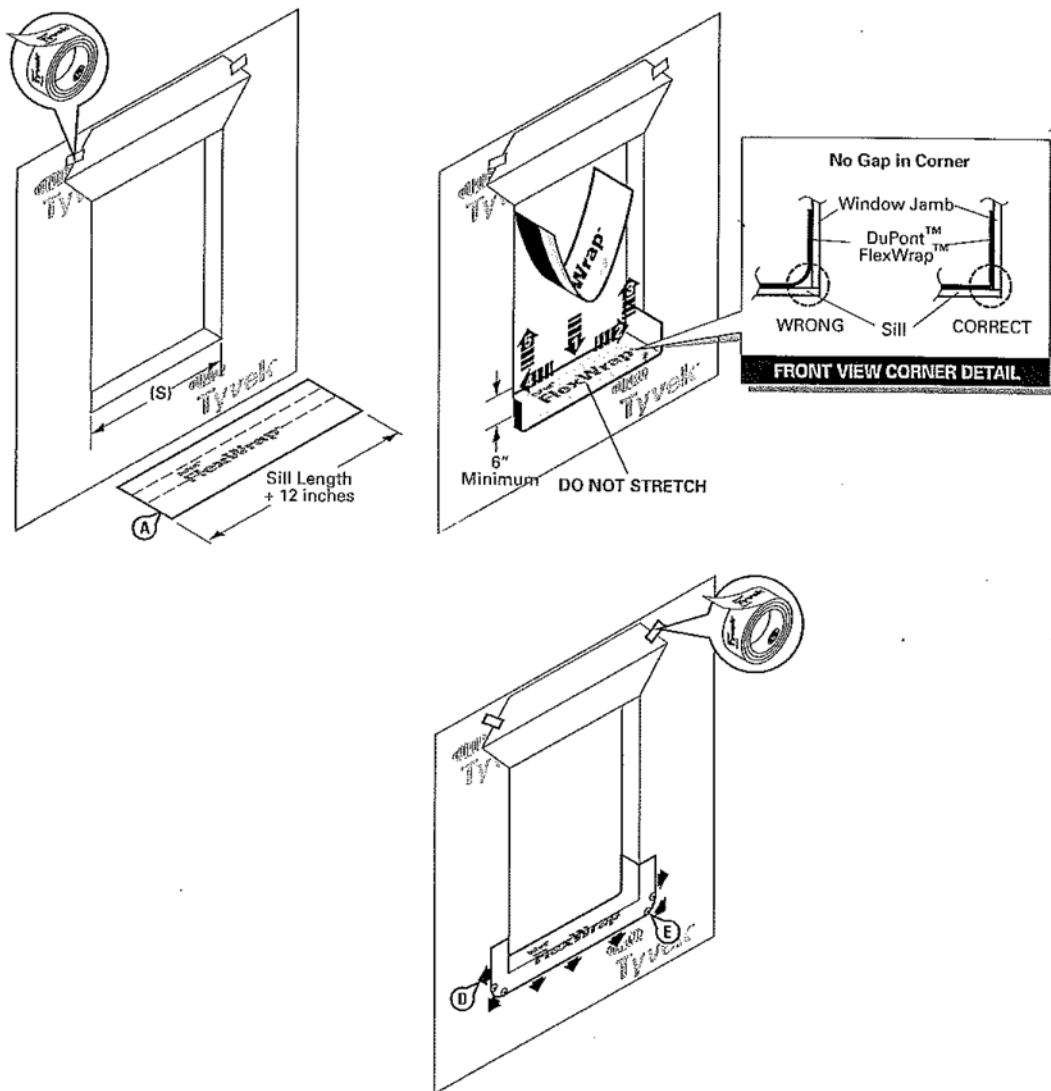

DuPont™ Flashing Systems Installation Guidelines

STEP 3

- A. Apply continuous bead of caulk at the window head and jambs to wall or back side of window mounting flange.

DO NOT APPLY CAULK ACROSS BOTTOM SILL FLANGE to allow for drainage.

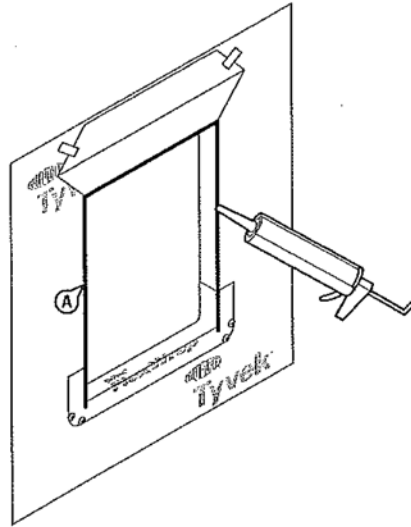

FOR RECTANGULAR WINDOWS

STEP 4

- A. Install window according to manufacturer's instructions.
- B. Cut two pieces of DuPont™ StraightFlash™ or DuPont™ FlexWrap™ for jamb flashing extending 1" above window head flange and below bottom edge of sill flashing. Remove release paper and press tightly along sides of window frame.
- C. Cut a piece of DuPont™ StraightFlash™ or DuPont™ FlexWrap™ for head flashing, which extends beyond outer edges of jamb flashings. Remove release paper and install completely covering mounting flange and adhering to exposed sheathing or framing members. (see C)

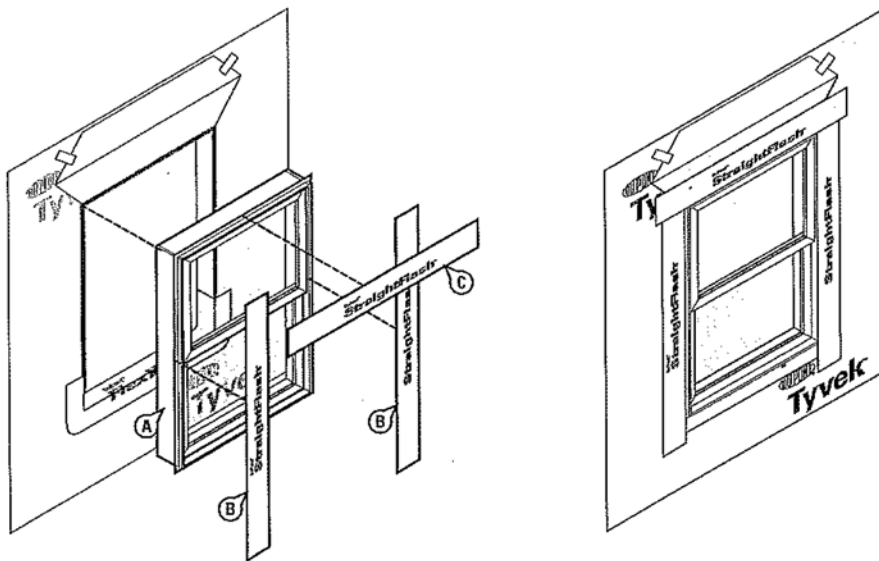

STEP 5

- A. Flip down upper flap of water-resistive barrier so it lays flat across head flashing.
- B. Tape along all cuts in water-resistive barrier and tape across head of the window with DuPont™ Tyvek® Tape.

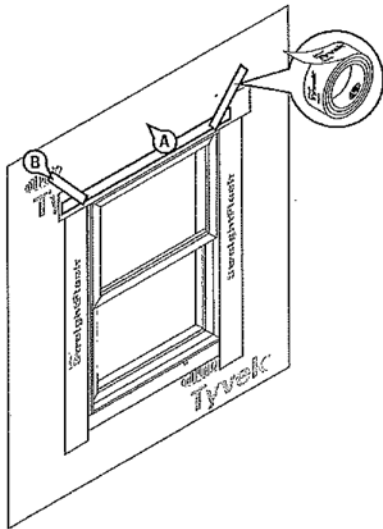

STEP 6 (optional / not required)

Final Step

Seal around the window opening at the interior, using caulk (and backer rod as necessary). Caulk and backer rod will also serve as a back dam.

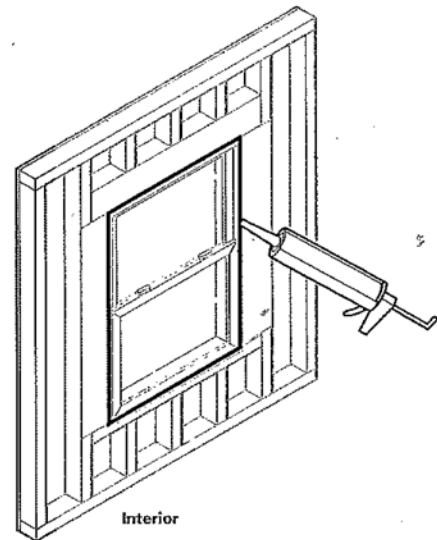

FOR ROUNDTOP WINDOWS

STEP 4

- A. Install window according to manufacturer's instructions.
- B. Cut two pieces of DuPont™ StraightFlash™ or DuPont™ FlexWrap™ for jamb flashing extending 1" above window head flange and below bottom edge of sill flashing. Remove release paper and press tightly along sides of window frame.

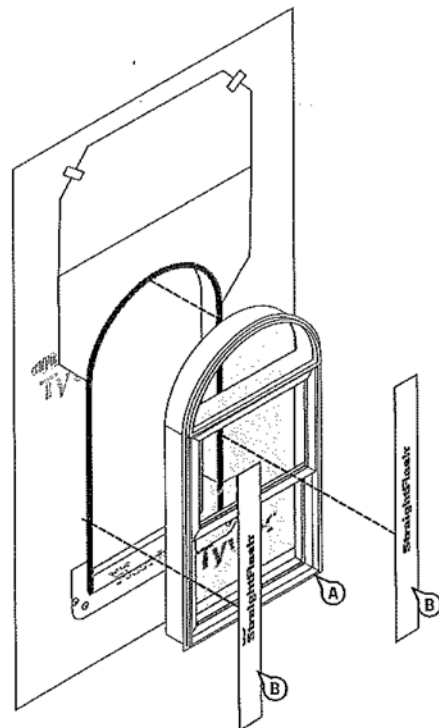

DuPont™ Flashing Systems Installation Guidelines

STEP 5

Install head flashing

- Cut head flashing at least 12" longer than the arc length (H) of round-top window.
- Remove both release papers and install to conform around top of window, covering entire mounting flange and adhering to exposed sheathing or framing members. Head flashing should overlap jamb flashings at least 6".
- Secure outer edges of head flashing using mechanical fasteners. e.g. DuPont™ Tyvek® Wrap Caps (nails, screws, staples). SECURE every 6" to 12" along outer perimeter.

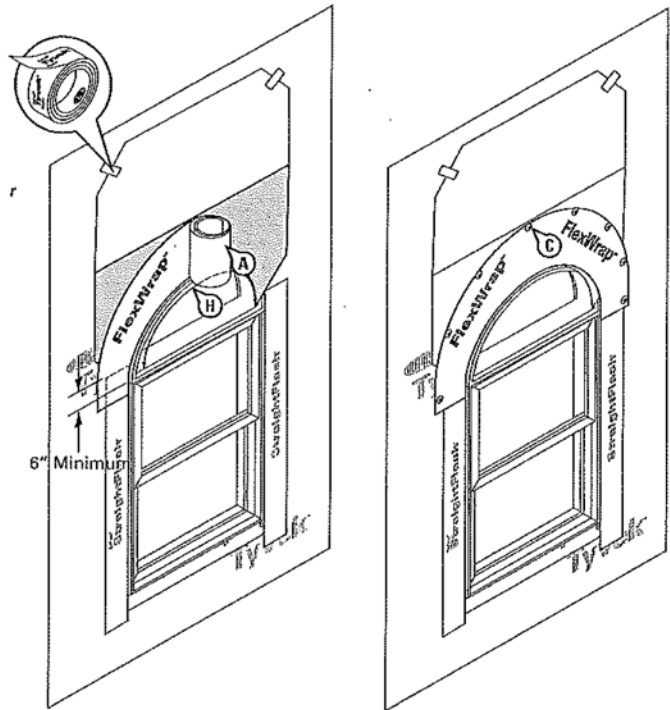

STEP 6

- Flip down upper flap of WRB so it lays flat across head flashing.
- Tape along all cuts in WRB and across head of the window with DuPont™ Tyvek® Tape.

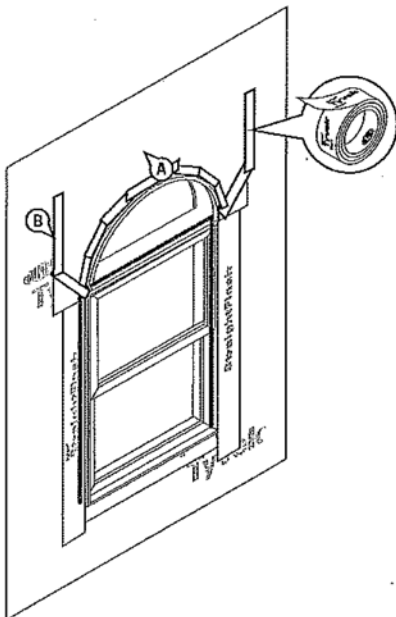

STEP 7

Final Step

Seal around the window opening at the interior, using caulk (and backer rod as necessary). Caulk and backer rod will also serve as a back dam.

