

CAD MODEL

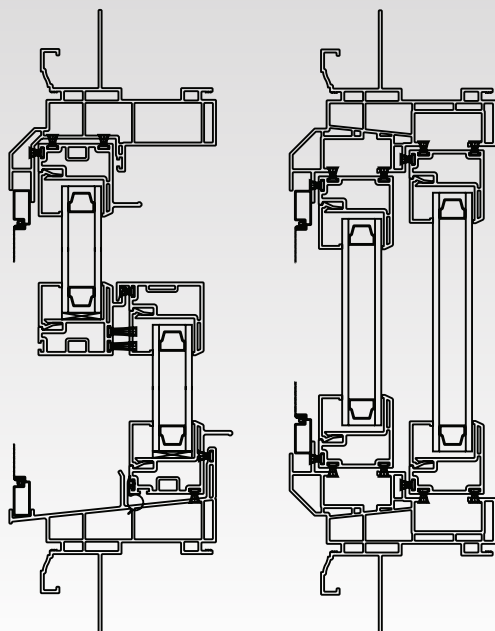

ASSEMBLY DRAWING



Custom Vinyl Products, LLC
 Window & Door

www.customvinyl.net

Locally Owned & Operated
 Products Certified 100% Lead Free



FEATURES and BENEFITS

- All welded frame and sash
- Sloped sill designed for efficient water evacuation.
- 3-1/4" frame width ideal for replacement installations
- Frame jambs designed to accept all balance types
- Integral Nail Fin and J Channel
- J channel designed with Brick Mold accents
- Aesthetically pleasing exterior frame design
- Full complement of accessory profiles
- Exterior glazed equal and unequal sash
- Multiple Glazing bead options using single or dual durometer
- Optimum designed aluminum sash reinforcement
- Maximum glass thickness of 1-1/8"
- Multi chambered vinyl profiles for thermal efficiency
- Triple weatherstripping
- Interlocks designed for ease of operation and positive engagement
- DP50 performance levels
- Full Family of products (Hung, Slider, Casement and Picture window(s))
- Pinnacle lamination available

MANUFACTURING LIMITATIONS

BASELINE PERFORMANCE

Thermal Insulation

GLASS	Uc Value	R Value
LoE/Argon	0.27	3.70
Double LoE/Argon	0.22	4.55
Double LoE/Krypton	0.19	5.26

Structural Performance

Air Infiltration @ 25 mph	0.09 cfm/ft ²
Water Penetration	7.50 psf
Uniform Loads	+/-75.00 psf

AAMA RATING: R-PG50-40 x 63H